

# Clause Structure in the Rai Dialect of the Kaili Language: A Descriptive Syntactic Study

Floryasita Wulinda<sup>1</sup>, Fitra Ramadhani<sup>2</sup>, Haerunnisa<sup>3</sup>, Ira Safitri<sup>4</sup>

<sup>1,2,3,4</sup>Tadulako University, Indonesia

---

## ARTICLE INFO

### Keywords:

Dependent; Derivation;  
Klausa Independent

### Article history:

Received 2026-04-14

Revised 2026-05-13

Accepted 2026-06-29

## ABSTRACT

Language is an important element in human life because it functions as a means of communication, conveying ideas, and a medium for inheriting cultural values from one generation to the next. This study aims to describe the structure, types, and rules of word formation through derivation, as well as the differences and syntactic relationships between independent clauses (free) and dependent clauses (bound) in the Kaili language of the Rai dialect, one of the varieties of Kaili language used in the Central Sulawesi region. The research uses a qualitative descriptive method; The data was collected through the Simak and Cakap method (interviews with native speakers, natural speech recordings), then analyzed using the matching and distribution method to identify the patterns, functions, and grammatical features. The results show that independent clauses can stand on their own as complete sentences, consisting of three main types: intransitive (without objects, S-P, P-S, and variations with adverbs), transitive (having objects, the basic pattern of S-P-O and its variations), and equivocal (connecting subjects and complements, without mandatory verbs). In contrast, dependent clauses cannot stand alone, function as part of compound sentences (as complements, adverbs, or adverbs), and are usually characterized by subordinate conjunctions or suffixes that mark syntactic dependencies on the main clause. At the morphological level, derivation is the process of forming new words with different meanings and classes of words, especially through suffixes (prefixes, suffixes, circumfixes) that are commonly used in this dialect. Suffixes such as na-, po-, ma-, pa- change the verb to a noun, change the active-passive meaning, or change the category of a word, for example from an adjective to a verb; This process becomes an important means of enriching vocabulary and composing more complex sentence structures. Overall, the syntactic and morphological system of the Rai dialect exhibits the characteristics of the Kaili language: a flexible but head-beginning pattern of word order, the productive use of suffixes for the derivation and marking of relationships between clauses, and a clear distinction between independent units and those that depend on sentence structure.

*This is an open access article under the CC BY SA license.*



---

## Corresponding Author:

Floryasita Wulinda

Tadulako University, Indonesia; [floriasita0@gmail.com](mailto:floriasita0@gmail.com)

---

## 1. INTRODUCTION

Language is an important element in human life because it functions as a means of communication, conveying ideas, and a medium for inheriting cultural values from one generation to the next. In addition to Indonesian as the national language, Indonesia has hundreds of regional languages that are

part of the national linguistic wealth. The existence of regional languages not only functions as a means of communication between communities, but also as a cultural identity that reflects the history, social values, and local wisdom of a community (Nugroho & Setiawan, 2022; Ark, 2021). In the context of cultural preservation, regional languages have a strategic role because they are the main media in maintaining traditions, customs, and knowledge systems of local communities (Mulyadi et al., 2023; Sari & Wahyuni, 2024). Therefore, research on regional languages is important to document and develop linguistic studies related to linguistic diversity in Indonesia (Rahmawati et al., 2022).

One of the regional languages that is still actively used by the people in Central Sulawesi is the Kaili language. The Kaili language is a language spoken by the Kaili tribe people spread across Palu City, Sigi Regency, Donggala, and several other areas in Central Sulawesi. This language belongs to the Austronesian language family and has a number of dialects that develop according to the region of its speakers, such as Kaili Ledo, Kaili Tara, Kaili Da'a, Kaili Rai, and several other dialects (Marten & Yusri, 2021; Mahsun, 2022). The diversity of dialects shows the linguistic richness of the Kaili people who still maintain the phonological, morphological, and syntactic characteristics of each speaking region (Halim & Arifin, 2023). In the midst of technological developments and the increasingly dominant use of the Indonesian language, documentation efforts for various dialects of the Kaili language are very important as a form of preservation of regional cultural heritage (Fauzi et al., 2024).

One of the interesting variations of the Kaili language to study is the Kaili Rai Dialect. The Rai dialect is used by some Kaili people in the Central Sulawesi region and has its own characteristics that distinguish it from other Kaili dialects. These differences can be seen in aspects of pronunciation, vocabulary, the use of affixes, and sentence structures used in daily communication (Nurdin & Latif, 2022). Despite having a number of linguistic differences, the Rai dialect remains an integral part of the Kaili language and serves as a means of communication, social identity, and a medium for cultural preservation of the speaking community (Yusuf et al., 2023). The study of dialects is not only important in efforts to document regional languages, but also contributes to the development of linguistics, especially in the field of syntax and typology of regional languages in Indonesia (Putri & Anwar, 2025).

In linguistic studies, syntax is a branch of linguistics that studies the relationships between words in forming meaningful phrases, clauses, and sentences. One of the important syntax units to study is clauses. Clauses are grammatical units that at least consist of predicates and have the potential to become sentences if they are equipped with other elements (Prasetyo & Hidayat, 2023). Clause analysis is important because through this study, it can be understood how speakers organize information, organize ideas, and build meaning in speech (Kusuma et al., 2024). In general, clauses are divided into two main types based on their degree of independence, namely independent clauses and dependent clauses. Independent clauses or free clauses are grammatical units that have a complete structure so that they can stand alone as complete and meaningful sentences. This type of clause generally contains a clear subject and predicate and does not depend on other elements to convey the message perfectly (Widodo & Santosa, 2022).

In compound sentences, independent clauses serve as the parent sentence that is the main information center. On the other hand, a dependent clause or a binding clause is a clause that cannot stand alone because its meaning is incomplete if it is not connected with other clauses (Fitriani & Nugraha, 2021). Dependent clauses are usually characterized by the presence of subordinate conjunctions or certain grammatical elements that indicate a dependency relationship to the main clause (Rahman et al., 2024). Through the analysis of the relationship between clauses, researchers can identify the pattern of information preparation used by speakers of a language and understand the grammatical mechanisms that shape meaning in speech (Sutrisno et al., 2023). This kind of study also contributes to the development of regional grammar descriptions that are still relatively limited, including in the Kaili Rai Dialect. In the perspective of generative grammar developed by Noam Chomsky, causative construction is understood as a process of derivation that adds a causer argument to the sentence structure so as to produce the meaning of 'causing someone or something to perform a certain action' (Hernandez & Kim, 2021). Causative derivation clauses are clauses that undergo

structural changes from their basic form so as to give rise to a cause-and-effect relationship between the perpetrator and the action taken. In various languages, causative constructs can be formed through morphological, syntactic, or lexical processes that indicate the causal role of an event (Lee & Nakamura, 2023).

Causative clauses have different characteristics than non-causative clauses. In the causative clause there is an explicit relationship between cause and effect, while in the non-causative clause the relationship is not found. The subject in the non-causative clause only performs an action or experiences a situation without causing the other party to perform a certain action (Wijayanti & Harsono, 2024). These differences can be seen in the structure of arguments, syntactic functions, and semantic relationships that build the meaning of sentences. In modern linguistic studies, causative and non-causative analysis is one of the important approaches to understanding the relationship between syntactic structure and the representation of meaning in a language (Chen & Thompson, 2022).

Studies on causative and non-causative derivation clauses in the Kaili Dialect Rai language are still relatively limited compared to research on other regional languages in Indonesia. In fact, each language has its own characteristics in forming causative and non-causative constructions that can enrich understanding of the syntactic variations of Austronesian languages (Arka, 2021; Putri & Anwar, 2025). Therefore, this research is important to describe the form, function, and characteristics of causative and non-causative derivation clauses in the Kaili Rai Dialect. The results of the research are expected to contribute to the development of regional language syntactic studies, support efforts to document the Kaili language, and become a reference source for linguistic research related to the structure of clauses and typologies of regional languages in Indonesia.

## 2. METHODS

The research on causative derivation clauses of the Kaili language of the Rai dialect in Sipeso Village used a qualitative research type. Qualitative research was chosen because this study aims to describe in depth the form, structure, and process of formation of causative derivation clauses in the Kaili language of the Rai dialect as used by native speakers. The qualitative approach allows researchers to obtain data in the form of speech, expressions, and sentences that contain causative elements naturally. The data is then analyzed based on the context of its use and its constituent elements so that a complete picture of causative derivation clauses in the Kaili dialect of Rai is obtained. This research is descriptive because the results of the research are presented in the form of descriptions, explanations, and grouping of data in accordance with the purpose of the research, without using statistical calculations. Sudaryanto (1991) also emphasized that in syntactic research, the identification of independent clauses is very important because this clause is the starting point for the analysis of compound sentence construction.

By identifying independent clauses first, researchers can more easily determine other clauses that have subordinate status and analyze the grammatical and semantic relationships between them. An analysis of a dependent clause should include at least three aspects, namely the identification of the subordinate marker that precedes the clause, the analysis of the grammatical function occupied by the subordinate clause in the structure of the main clause, and the description of the relationship of meaning that exists between the subordinate clause and the main clause. These three aspects are the framework for standard analysis in descriptive and systematic dependent clause research. Derivation clauses in syntactic studies refer to clauses that are formed through the process of degradation or transformation from other more basic clause structures. Sudaryanto (1991) explained that in syntactic research, derivation is understood as the process of forming new grammatical constructions derived from or derived from existing constructions, either through morphological processes or through syntactic transformations. Thus, this study aims to describe in depth the types of independent, derivative, and dependent clauses, as well as the function of the meaning of clauses in the kaili language based on data obtained from native speakers in Sipeso Village, Sindue Tobata District, Donggala Regency.

In linguistic research, data collection can be done through two main methods, namely, the simak method and the cakap method. (Sudariyanto, 2015) a. The method of observation is: 1). Eavesdropping technique, the researcher taps or records the speech of informants when using the Kaili language of the Rai dialect. 2). The free and engaging (SBLC) technique, the researcher only listens to the informant's conversation without being directly involved in the conversation. 3). Recording technique, Data that is considered important is recorded in a notebook or research data sheet. 4). Recording technique, The informant's speech is recorded using a recording device so that the data obtained is more accurate and can be played back during analysis. b. Capable techniques, namely: 1). Face-to-face proficiency technique, the researcher conducted a direct interview with the informant about the use of the Kaili dialect of Rai. 2). fishing technique, the researcher provides questions or example sentences to provoke informants to produce speech that contains clauses

### 3. FINDINGS AND DISCUSSION

Based on the results of research obtained from informants in Sipeso village, Sindue Tobata District, Donggala Regency. Types and structures of clauses are found in the kaili language of the rai dialect. An independent clause is a stand-alone clause, having a complete meaning, independent of other clauses, consisting of the element of Subject (S) + Predicate (P), can be added Object (O) or Description (K), which consists of, transitive, intransitive, and equitable. As for causative and non-causative derivation clauses, causative derivation clauses are clauses formed through the process of change or formation of words (derivation) with the addition of certain suffixes, which give the meaning of causing, creating, commanding, or causing a situation or event to occur, the type consists of, clauses from intransitive, monotransitive, reciprocal, adjective, and adverb. A noncausative derivation clause is a clause formed through the process of change or formation of the word (derivation) without adding a causal or causal meaning, which consists of active-passive, bitransitive, reciprocal, reflective, and semitransitive clauses. A dependent clause (often also called a bound clause or subordinate clause) is a clause that cannot stand alone as a whole sentence, even though it has the essential elements of the sentence (Subject and Predicate). This clause must be combined or dependent on another more complete clause (called an independent/main clause) in order to have a clear and complete meaning consisting of, noun clauses on subjects, objects, complements, adjectives and adverbs.

#### Discussion of Independent Clauses, Derivation Clauses, and Dependent Clauses in the Kaili Language of the Rai Dialect

Based on data collected from native speakers of the kaili language of the rai dialect in Sipeso village, Sindue Tobata district, Donggala Regency, Central Sulawesi Province, it was found that

##### Klausa independent

##### Transitive independent clauses in the kaili language of the rai dialect (S-P-O)

This clause is a transitive independent clause because the predicate is in the form of a verb that requires an object as a complement to the meaning. The pattern of clauses formed is S-P-O, namely the subject as the perpetrator, the predicate as the action, and the object as the object of the action.

Toai nosepa bala = Brother kicks the ball

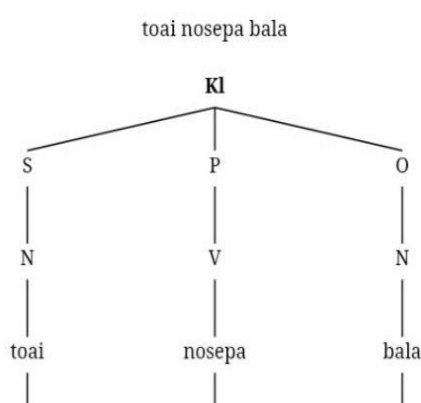

The clause "toai nosepa bala" is composed of three constituent elements, namely Subject (S), Predicate (P), and Object (O). The element of toai is in the noun (N) category that functions as a subject, namely the perpetrator or the party who performs the action. The nosepa element is a verb (V) that functions as a predicate and expresses the actions performed by the subject. The element of reinforcement is in the noun category (N) which functions as an object, which is the target of the action expressed by the predicate. Thus, the structure of the clause can be formulated as follows:

- KL → S + P + O
- S → N (toai)
- P → V (nosepa)
- O → N (bullet)

**Independent intransitive clauses in the language of the rai dialect (S-P)**

The clause pattern shows that the clause is formed by one subject and one predicate without any object or description, so it includes a simple clause with an S-P pattern

Crying = Crying Baby  
nganakodi notumangi

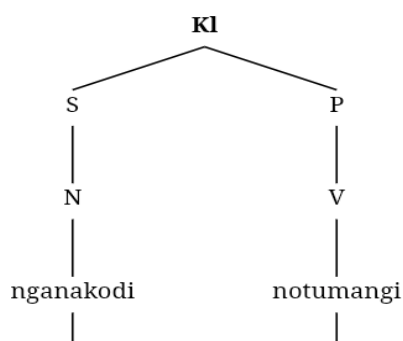

The clause "nganakodi notumangi" is an independent clause with an S-P pattern (Subject-Predicate). The nganakodi element is in the noun category (N) which functions as the subject (S), while the notumangi element is in the verb category (V) which functions as the predicate (P). Thus, the structure of this clause can be formulated as:

- KL → S+P
- S → N (Ganakodi) P
- V
- (Demonetisation)

**Equatorial independent clauses in the kaili language of the rai dialect (S-P)**

This clause is an independent clause in the S-P pattern, with a predicate that is expanded by an accompanying element in the form of a prepositional phrase so as to provide more complete information about the predicate core. b. Njau natuntoru shoes = The shoes look dirty.

I know ri palu = I'm a hammer person

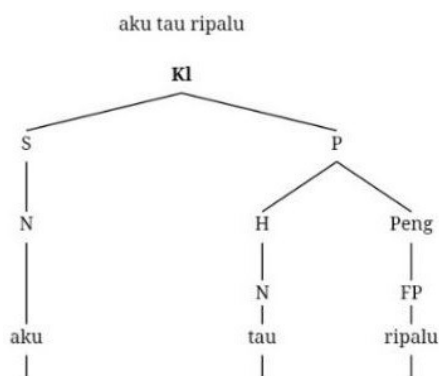

The clause "I know ripalu" consists of the elements of Subject (S) and Predicate (P). The I element is in the noun category (N) which functions as a subject. Predicates are formed by the tau element as the head (H) or the predicate core which is in the noun category, as well as the ripalu element which is in the prepositional phrase (FP) category and functions as an accompaniment/complement to the predicate. Thus, the structure pattern of the clause can be formulated as follows:  $KI \rightarrow S + P$

$S \rightarrow N$  (me)

$P \rightarrow H+Peng$

$H \rightarrow N$  (year)

$Peng \rightarrow FP$  (ripalu)

### Causative derivation clause

#### Intransitive causative derivation clauses in the language of the rai dialect kaili

Dates (1)

1. Anak mandi : "ngana nandiu"  
Mother bathes the child : "Ina Pakandiu ngana"
2. And then he said, "Okay, I'm going to do it."  
Mother puts the baby to sleep : "Ina nompaturu ngana"
3. The child laughed: "ngana nokaele"  
Mother laughed at the child : "Ina mompakaka nokaele ngana"
4. Sister crying : "ademu notumangi"  
Sister made her sister cry: "Your old man is now your tuaimu tumangi"

An intransitive clause is a clause whose predicate is an intransitive verb, which is a verb that does not require an object to complete its meaning. In this clause, the elements that must be present are usually only the subject and the predicate.

#### Monotransitive causative derivation clause in the language of the rai dialect kaili

Data (2)

1. Baby drinking milk : "ngana kodi netomi"  
Mother drinking baby milk : "ina nompatomi ngana"
2. Students see photo : "Student mompetuka photo"  
He showed the photo to the student: "he took the photo in front of the student"
3. Ani writes poetry : "ani notation poem"  
Guru writes ani poem : "guru nompopotulisika ani poem"
4. Budi drawing house : "budi nogambara banua"  
Anto describes the housewife: "anto nogambaraka budi banua"
5. Sinta sweeps the floor : "Sinta nosaewe jaula"  
Mother sweeps the floor sinta : "ina nosaeweka sinta jaula"

A monotransitive clause is a clause whose predicate is a transitive verb that requires only one object to complete its meaning. This clause consists of a subject, a predicate, and one object as the core element

#### Reciprocal causative derivation clauses in kaili language

Data (3)

1. Alvin and fian fight: "Alvin and fian nosisalaka"  
Dea quarrels with alvin and fian: "dea nosisalaka alvin and fian"
2. Andri and rya get acquainted: "andri and rya mosikenal"  
Agung introduces Andri and Rya: "Agung Mosikenalaulu Andri and Rya"

3. Amel and Yula hug : "Amel and Yula Nosikapui"  
Gia hugged Amel and Yula: "Gia nosikapui amel and Yula"
4. Desman and imel shaking hands: "Desman and imel nosijuju"  
Desi greets Desman and imel : "desi nosijujuka desman and imel"
5. Via and alda talk: "via and alda nojarita"  
Vito talks about via and alda : "vito nojaritaka via and alda"

A reciprocal clause is a clause that states a reciprocal relationship or action between two or more parties. In this clause, each participant acts as a perpetrator as well as a recipient of the action.

### **Causative derivation clauses of adjectives in kaili language**

Data (4)

1. Clean house : "banua nafoe"  
Razak cleaned the house : "razak nompakafoe banua"
2. Beautiful Garden : "Taman Nagaya"  
Flora beautify it: "flora nompakagaya taman njau"
3. Light color : "color nareme"  
Alvin explains the color: "Alvin nompakareme the color of the tree"
4. Rambut panjang : "nalonggo wo'o"  
Amel lengthened the hair: "Amel seems to be longgo wo'o"

An adjective clause is a clause whose predicate is an adjective (adjective) that serves to express the nature, state, or condition of the subject. In this clause, the adjective becomes the main element that describes the condition of the subject without the need for a verb as a predicate

### **Causative derivation clause of adverbs in kaili language**

Data (5)

1. Sleep well: "Descendants of the Nation"  
Rio said softly: "Rio is a descendant of the descendants."
2. Her speech is soft: "nojarita nalera"  
Fitri slowed down her speech: "Fitri nompakalera nojaritana"
3. Late arrival: "nasonda nalera"  
Ria slows down her work: "ria nompakalera her work"
4. The voice is loud : "the voice is nadiki"  
The DEA hardens its voice: "the dea seems to have its voice"
5. Wide road : "jala nakemba"

The government widens its path: "government nompakalemba jala" The causative clause of an adverb is a clause whose predicate is formed from the element of adverb (adverb) that undergoes a causative process so as to show the meaning of causing a certain situation, way, time, or situation to occur.

### **Active-passive non-causative derivation clauses in the language of the Rai dialect kaili**

Data (6)

1. Rio eats rice : "rio nokumoni kanisa"  
Rice eaten by rio: "konisa nikoni by rio"
2. Razak opens the door : "razak nobuka boboka" The door is opened  
by razak : "boboka nibuka by razak"
3. Dito wrote a letter : "dito notated letter"  
Letter written by dito: "Letter of Nitulisi by dito"
4. Dita washing clothes: "Dita nontoposi clothes"  
Clothes washed by dita " nintoposi clothes by dita"

5. Adam read the book : "adam nombasa book" book read by adam : book read by adam"
6. Ario buys cake: "ario nagoli gode"  
Cake bought by ario : "gode nioli by ario"
7. Flo cooking vegetables : "flo nompoapu uta"  
Vegetables cooked by flo : "uta nimpupu by flo"
8. Sinta kicking the ball: "sinta nosepa bola"  
Ball kicked by sinta: "nisepa ball by sinta"
9. Budi drinking milk : "Budi nominu susu"  
Milk is drunk by the bud : "milk is drunk by the bud"
10. Dila Brings Water: "Dila Nonggeni EU"  
Water is carried by the tongue : "ue ninggeni by the tongue"

Active and passive clauses are two forms of clauses that are differentiated based on the role of the subject in an action

### **Bitransitive non-causative derivation clauses of the rai dialect kaili language**

Data (7)

1. Dita membelikan nenek kue : " dita nagolika nene gade"
2. Rio makes a coffee grandmother: "rio nompesiayu a coffee grandmother"
3. Razak reads his younger brother's story: "razak nobacaka reaps the story"
4. A Student Assignment Assignment: "A Student Assignment Assignment"
5. Dito wrote a letter to his sister: "dito notulisika harvest letters"
6. Mother cooking flo rice : "ina nompuapuka flo kanisa"
7. Mother sewing sister's shirt: "ina nojauka tuai bakea"
8. Sister brings mother cake : "toaka nonggenika ina gade"
9. Rina S. Scott: "Rina Scott"
10. Budi drinking milk sister : "budi niminuka tuai susu"

A bitransitive clause is a clause whose predicate requires two complementary elements, namely the object and the complementary.

### **Reciprocal non-causative derivation clauses in the language of the Rai dialect**

Data (8)

1. Amir punches Umar: "Amir nojaguru Umar"  
Amir and Umar Bakutinju : "Amir and Umar Mosijaguru"
2. Jaki loves Rina: "Jaki notengea ante Rina"  
Jaki and Rina : "Jaki and Rina Mosimpokono"
3. Wandu greets andri : "wandi nosikadepaka andri"  
Wandi and Andri greet each other: "Wandi and andri nosikadepaka poro"
4. Rika helps Riko : "Rika Nosiporoaka Riko"  
Rika and Riko help each other : "Rika and Riko nesiporoani"
5. Dini forgives dita: "dini medodoampu dita"  
Dini and Dita forgive each other: "Dini and Dita nosiampungu mpungi."

A reciprocal clause is a clause that states a reciprocal or mutual relationship between two or more parties.

### **Reflective non-causative derivation clauses in the language of the Rai dialect kaili**

Data (9)

1. Lina committed suicide: "Lina no killed Koro"
2. Tia beautify herself : "tia nompegaya koro"
3. Fitri take care of herself : "fitri jagai koro"
4. Yula martial arts : "Yula nolava koro"
5. Eko Confident: "Eko Nono Koro"
6. Siti decorating herself: "Siti nompegaya koro"
7. Rudy Menibu Tri: "Rudi Nedavai Koro"
8. Lina tortured herself: "Rina nepetorsa koro"
9. Eki poisoning himself: "eki poison the city"
10. Joko measures himself: "Joko noukuru koro"

A reflexive clause is a clause in which the action of the perpetrator returns to himself.

### Semitransitive non-causative derivation clauses in kaili language

Data (10)

1. Ikfar merotan : "ikfar nelauro"
2. Rani Painting : "Rani Nogambara"
3. Dita menenun: "Dita Nontanu"
4. From the Heart: "The Golden Globe"
5. Here it is : "Here is the bride's house"
6. Kea weaving: "kea nokoi"
7. Lidya batik : "Lidya nobomba"

A semitransitive clause is a clause whose predicate an object can follow, but the object does not always have to be present so that the clause remains understandable.

### Klausa dependen

#### Finally payscot

A noun clause is a dependent clause that occupies the function of a noun in a sentence. Noun clauses in the Kaili language of the Rai dialect can be positioned as subjects, objects, or complements to sentences. Structurally, this clause is composed of the elements of the nominal phrase (FN) as the subject and the verbal phrase (FV) as the predicate, and its presence in the main sentence serves to replace the position of the ordinary noun.

#### Noun Clause in Subject Position

The noun clause in the subject's position is a dependent clause that occupies the function of the subject in the sentence. The entire clause replaces the role of the ordinary noun as the topic of the sentence described by the predicate. In the Kaili dialect of Rai, this pattern is usually marked by the presence of a nominal phrase followed by an adjunct that explains the subject.

Dates (1)

(the child cried at his mother's stay)  
Ngana njau notumangi nipalenaka inona

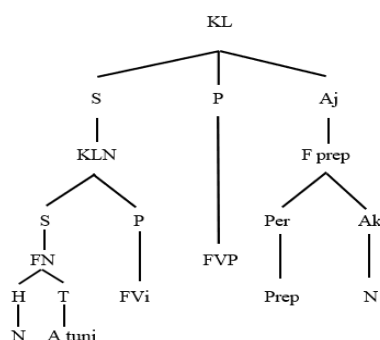

### Noun clauses on objects

A noun clause in the position of an object is a dependent clause that fills in the function of an object or verbal complement in a sentence. In the Kaili dialect of Rai, this clause generally follows the predicate of a transitive verb and as a whole describes the action ordered or requested by the main subject.

Data (2)

(father tells his son to go to the garden)  
A Man Who Was Born To Be A Vampire

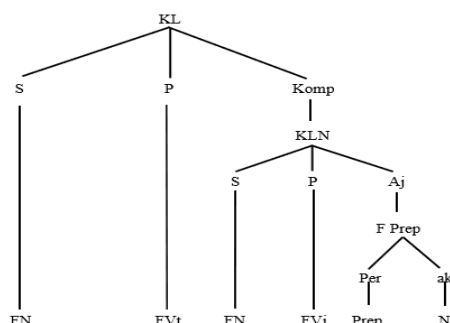

### Noun clauses in complements

The noun clause in the complement position is a dependent clause that fills the function of the complement of the copulative predicate. In the Kaili language of the Rai dialect, this pattern usually appears in the construction of an equatory sentence that uses the copula 'is', where the noun clause is present as a constituent that describes the identity or nature of the subject.

Data (7)

(Andi is a child who likes to play football)  
It's Not A Bullet Hole

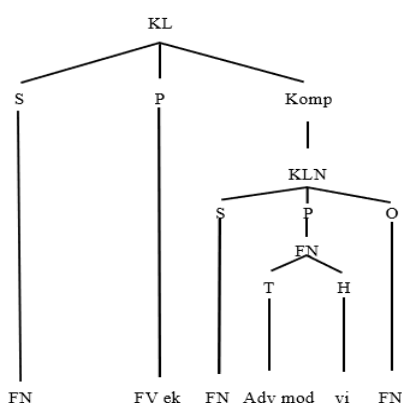

Data (7) shows a noun clause that functions as a complement in an equational sentence. The subject of the sentence is 'Andi' (self-name), the predicate is filled by the copula 'is', and the complement is the noun clause 'ngana nompokono nomore bala' (a child who likes to play football). Internally, this complement clause is composed of FN 'ngana' as the head described by the attributive clause 'nompokono nomore bala'. The adverb of the modality 'nompokono' (like) becomes a marker of the subject's disposition or habits. The T-H (Pewatas-Head) pattern in the FN complement confirms that this dependent clause plays a role in identifying the characteristics of the referent.

### Klausa adjective

An adjective clause is a dependent clause that functions like an adjective, i.e. it describes the core noun in a nominal phrase. In the Kaili language of the Rai dialect, the adjective clause is characterized by the presence of the relative pronoun 'anu' which serves as a connecting link between the core noun and its illuminating clause. The adjective clause is always in FN and fills the position of the adjective

(T) behind the noun head (H).

Data (10)

(The person who stole the wallet has been arrested by the police)

A man who was shot in the head by the police

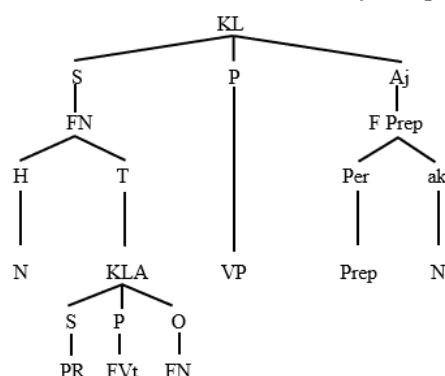

Data (10) displays an adjective clause marked by the relative pronoun 'anu' (yang). The core noun 'tau' (person) as head (H) is explained by the adjective clause 'anu nogangga dompe' (who steals the wallet) as a guardian (T), forming a complex FN. This adjective clause internally consists of PR 'anu', FVt 'nogangga' (steal), and FN object 'dompe' (wallet). The predicate of the main sentence is filled by the passive verbal phrase 'risoko polisi' (arrested by the police) which describes the events experienced by the complex FN as the subject.

**Klausa adverbial**

An adverb clause is a dependent clause that functions like an adverb, that is, it describes the predicate of the main clause. Adverb clauses in the Kaili language of the Rai dialect are characterized by the presence of time subordinative conjunctions (K Sub) such as 'time' (when) and 'raipa' (before) that connect the parent clause with the dependent clause. Adverb clauses generally fill the position of the adverb (K) in the sentence structure and describe the temporal conditions of the events in the main clause.

Data (13)

(she was singing When we came)

He was a member of the Congregation of the Congregation

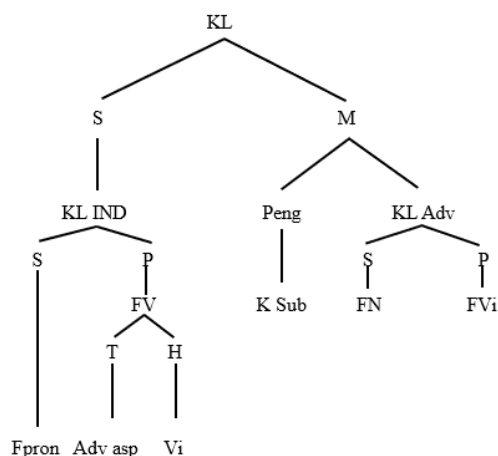

Data (13) displays a temporal adverb clause characterized by the subordinative conjunction 'time' (when). The parent clause 'he while nomanyanyi' (he is singing) has the subject 'he' (he), the durative aspect 'temporary' (medium), and the verb 'nomanyanyi' (singing). The adverb clause 'when we arrived' (when we came) occupies the position of a statement stating the time of occurrence of the

event in the parent clause. The conjunction 'time' serves as a temporal subordinate marker as well as being the constituent that initiates the dependent clause.

#### 4. CONCLUSION

Based on the results of the analysis of syntactic and morphological structures in the Kaili dialect of Rai, it can be concluded that this diverse grammatical system has regular, interrelated, and functional rules to meet the communication needs of its speakers. Each grammatical element has its own distinctive characteristics, functions, and roles, but they work together in a unified system to form clear and meaningful speech. In terms of syntax, clauses are the basic units that form sentences that are divided into two main types based on their independence, namely independent clauses and dependent clauses. Independent clauses have a complete structure and complete meaning, so they can stand on their own as valid sentences; In a compound sentence, it ranks as the main clause that is the core of the message. On the other hand, a dependent clause cannot stand alone because its meaning is not yet complete, so it must join an independent clause to complete the information, serve as a caption, guardian, or complement. In the Rai dialect, the difference between the two is characterized by the existence of subordinate conjunctions or special suffixes in dependent clauses, as well as a fixed but flexible pattern of word sequence following the head-beginning principle that characterizes the Kaili language. In terms of morphology, derivation is a very productive process of word formation and plays a major role in enriching vocabulary and changing the function of words as needed. Based on the resulting meaning, derivations are differentiated into two forms, namely causative derivation and non-causative derivation. Causative derivation, which is generally characterized by the suffix *pa-*, produces the meaning of an action that causes something to happen or makes something in certain circumstances, which has an impact on increasing the element of the sentence and forming clauses that tend to be transitive. Meanwhile, non-causative derivations that are characterized by suffixes such as *ma-*, *po-*, *na-*, change the meaning or class of words without adding the meaning of the cause, to express an active action, circumstance, reciprocal relationship, or event that has occurred; This process can form both intransitive and transitive clauses according to the meaning conveyed.

#### REFERENCES

- Aifa, H. N., & Asrianti, A. (2025). Struktur Klausa Independen Bahasa Kaili Dialek Rai. *Jurnal Onoma: Pendidikan, Bahasa, dan Sastra*, 11(4), 112–126.
- Aikhenvald, A. Y. (2022). *The languages of the world*. Oxford University Press. <https://doi.org/10.1093/oso/9780198852885.001.0001>
- Arka, I. W. (2022). *Balinese and Eastern Indonesian languages: Typological and syntactic perspectives*. Berlin, Germany: De Gruyter Mouton. <https://doi.org/10.1515/9783110733859>
- Badan Pengembangan dan Pembinaan Bahasa. (1998). *Tata Bahasa Kaili*. Jakarta: Departemen Pendidikan dan Kebudayaan.
- Baker, M. C. (2022). *Syntactic theory and the structure of language*. Cambridge University Press. <https://doi.org/10.1017/9781108993865>
- Bickel, B., & Nichols, J. (2021). Grammatical relations typology. In A. Y. Aikhenvald & R. M. W. Dixon (Eds.), *The Cambridge handbook of linguistic typology*. Cambridge University Press. <https://doi.org/10.1017/9781316135712>
- Blust, R. (2013). *The Austronesian languages*. Canberra, Australia: Asia-Pacific Linguistics. <https://doi.org/10.15144/PL-D17>
- Carnie, A. (2021). *Syntax: A generative introduction* (5th ed.). Wiley-Blackwell.
- Chaer, A. (2014). *Linguistik Umum*. Jakarta: Rineka Cipta.

- Comrie, B. (2023). *Language universals and linguistic typology: Syntax and morphology* (4th ed.). The University of Chicago Press.
- Croft, W. (2022). *Morphosyntax: Constructions of the world's languages*. Cambridge University Press. <https://doi.org/10.1017/9781108672456>
- Croft, W. (2023). *Typology and universals* (3rd ed.). Cambridge University Press. <https://doi.org/10.1017/9781108957928>
- Crystal, D. (2022). *The Cambridge encyclopedia of language* (4th ed.). Cambridge University Press. <https://doi.org/10.1017/9781108528937>
- Dixon, R. M. W. (2024). *The essence of linguistic analysis: An introduction to grammatical theory*. Oxford University Press. <https://doi.org/10.1093/oso/9780198906052.001.0001>
- Dryer, M. S. (2022). Word order. In M. Aronoff (Ed.), *Oxford Research Encyclopedia of Linguistics*. Oxford University Press. <https://doi.org/10.1093/acrefore/9780199384655.013.200>
- Dryer, M. S., & Haspelmath, M. (Eds.). (2013). *The World Atlas of Language Structures Online*. Max Planck Institute for Evolutionary Anthropology. <https://wals.info>
- Ewing, M. C. (2021). Clause combining and information structure in Austronesian languages. *Oceanic Linguistics*, 60(2), 321–345. <https://doi.org/10.1353/ol.2021.0015>
- Haspelmath, M. (2021). *Understanding morphology* (3rd ed.). Routledge. <https://doi.org/10.4324/9780429503760>
- Haspelmath, M., & Sims, A. D. (2023). *Understanding morphology* (3rd ed.). Routledge. <https://doi.org/10.4324/9780429503760>
- Hilda. (2024). Klitika Bahasa Kaili Dialek Rai [Skripsi]. Palu: Universitas Tadulako. Evans, D. (1992). Causation in Kaili. Dalam H. Steinhauer (Ed.), *Languages of Sulawesi* (hlm. 173–189). Jakarta: Universitas Indonesia Press.
- Himmelman, N. P. (2022). Language documentation and language description. *Annual Review of Linguistics*, 8, 251–271. <https://doi.org/10.1146/annurev-linguistics-030521-042744>
- Khairah, M., & Ridwan, S. (2022). *Sintaksis: Memahami Satuan Kalimat Perspektif Fungsi*. Jakarta: Bumi Aksara.
- Kridalaksana, H. (2008). *Kamus Linguistik*. Jakarta: Gramedia Pustaka Utama.
- Kroeger, P. R. (2022). *Analyzing syntax: A lexical-functional approach* (2nd ed.). Cambridge University Press. <https://doi.org/10.1017/9781108957744>
- Lehmann, C. (2021). *Thoughts on grammaticalization* (4th ed.). Language Science Press. <https://doi.org/10.5281/zenodo.5794070>
- Lehmann, C. (2022). Clause linkage and grammaticalization in language evolution. *Linguistics*, 60(4), 921–948. <https://doi.org/10.1515/ling-2022-0025>
- Mithun, M. (2022). Clause structure and clause linkage in the world's languages. In K. Allan (Ed.), *The Oxford handbook of linguistic analysis* (2nd ed., pp. 489–514). Oxford University Press. <https://doi.org/10.1093/oxfordhb/9780192895659.013.20>
- Payne, T. E. (2021). *Describing morphosyntax: A guide for field linguists* (2nd ed.). Cambridge University Press. <https://doi.org/10.1017/9781108634072>
- Payne, T. E. (2022). Clause structure and constituent order in language description. *Linguistic Discovery*, 20(1), 45–67. <https://doi.org/10.1349/PS1.1537-0852.A.482>
- Pertiwi, G., Lembah, H. G., & Ulinsa, U. (2019). Pemertahanan Bahasa Kaili Dialek Rai di Kelurahan Taipa Kecamatan Palu Utara. *Jurnal Bahasa dan Sastra*, 5(2),
- Riesberg, S. (2023). Voice, valency, and argument realization in Austronesian languages. *Oceanic Linguistics*, 62(1), 1–29. <https://doi.org/10.1353/ol.2023.0001>
- Riesberg, S., Malcher, A., & Himmelman, N. P. (2022). Voice systems and argument structure in western Austronesian languages. *Annual Review of Linguistics*, 8, 151–172. <https://doi.org/10.1146/annurev-linguistics-031220-010558>
- Shopen, T. (Ed.). (2023). *Language typology and syntactic description: Clause structure* (3rd ed.). Cambridge University Press. <https://doi.org/10.1017/9781316118777>

- Sofyan, I. A. (1979). *Morfologi dan Sintaksis Bahasa Kaili*. Jakarta: Pusat Pembinaan dan Pengembangan Bahasa.
- Sofyan, I. A. (1984). *Sistem Perulangan Bahasa Kaili*. Jakarta: Pusat Pembinaan dan Pengembangan Bahasa.
- Song, J. J. (2022). *The Oxford handbook of linguistic typology* (2nd ed.). Oxford University Press. <https://doi.org/10.1093/oxfordhb/9780198796806.001.0001>
- Song, J. J. (2023). *Linguistic typology: Morphology and syntax across languages*. Oxford University Press. <https://doi.org/10.1093/oso/9780192888880.001.0001>
- Sudaryanto. (1993). *Metode dan Aneka Teknik Analisis Bahasa*. Yogyakarta: Gadjah Mada University Press
- Tallerman, M. (2020). *Understanding syntax* (5th ed.). Routledge. <https://doi.org/10.4324/9780429462920>
- Ulinsa, U. (2020). Representasi Makna Verbal dan Fungsi dalam Pepatah Bahasa Kaili Dialek Rai. *Semotika*, 21(2), 82–92.
- Van Valin, R. D. (2021). *An introduction to syntax*. Cambridge University Press. <https://doi.org/10.1017/9781108569343>
- Van Valin, R. D., & LaPolla, R. J. (1997). *Syntax: Structure, meaning and function*. Cambridge University Press. <https://doi.org/10.1017/CBO9781139166795>
- Verhaar, J. W. M. (2021). *Asas-asas linguistik umum* (Revised ed.). Gadjah Mada University Press.
- Wouk, F., & Ross, M. (Eds.). (2022). *The history and typology of western Austronesian voice systems*. Pacific Linguistics. <https://doi.org/10.15144/PL-660>
- Zúñiga, F., & Kittilä, S. (2019). *Grammatical voice*. Cambridge University Press. <https://doi.org/10.1017/9781316671401>